

EXH. 12 OF 13

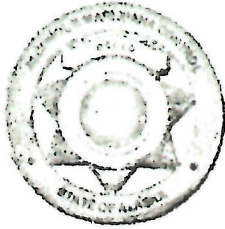

Alcohol and Marijuana Control Office
550 W 7th Avenue, Suite 1600
Anchorage, AK 99501
alcohol.licensing@alaska.gov
https://www.commerce.alaska.gov/web/amlc
Phone: 907.269.0350

Alaska Alcoholic Beverage Control Board

Form AB-03: Restaurant Designation Permit Application

What is this form?

A restaurant designation permit application is required for a licensee desiring designation under 3 AAC 304.715 – 3 AAC 304.795 as a bona fide restaurant, hotel, or eating place for purposes of AS 04.16.010(c) or AS 04.16.049. Designation will be granted only to a holder of a beverage dispensary, club, recreational site, golf course, or restaurant or eating place license, and only if the requirements of 3 AAC 304.305, 3 AAC 304.725, and 3 AAC 304.745, as applicable, are met. A detailed floor plan of the proposed designated and undesignated areas of the licensed business and a menu or expected menu listing the meals to be offered to patrons must accompany this form. Applicants should review AS 04.16.049 – AS 04.16.052 and 3 AAC 304.715 – 3 AAC 304.795. All fields of this form must be completed. The required \$50 permit fee may be made by credit card, check, or money order.

Section 1 - Establishment Information

Enter information for licensed establishment.

Licensee:	GLEN THOMAS				
License Type:	RESTAURANT EATING PLACE	License Number:	5568		
Doing Business As:	NINIKCHIK 132-6 CABINS AND R.V. PARK				
Premises Address:	13364 STERLING HWY				
City:	NINIKCHIK	State:	AK	ZIP:	99639
Contact Name:	GLEN THOMAS	Contact Phone:	907-252-6326		

Section 2 - Type of Designation Requested

This application is for the request of designation as a bona fide restaurant, hotel, or eating place for purposes of AS 04.16.010(c) or AS 04.16.049, and for the request of the following designation(s) (check all that apply):

- Dining after standard closing hours: AS 04.16.010(c)
 - Dining by persons 16 – 20 years of age: AS 04.16.049(a)(2)
 - Dining by persons under the age of 16 years, accompanied by a person over the age of 21: AS 04.16.049(a)(3)
 - Employment for persons 16 or 17 years of age: AS 04.16.049(c)
- NOTE: Under AS 04.16.049(d), this permit is not required to employ a person 18 - 20 years of age.

OFFICE USE ONLY					
Issue Date:		Transaction #:	15309	BRE:	808





Alcohol and Marijuana Control Office
 550 W 7th Avenue, Suite 1600
 Anchorage, AK 99501
alcohol.licensing@alaska.gov
<https://www.commerce.alaska.gov/web/amco>
 Phone: 907.269.0350

Alaska Alcoholic Beverage Control Board

Form AB-03: Restaurant Designation Permit Application

Section 3 - Additional Information

Enter all hours that your establishment intends to be open. Include variances in weekend/weekday hours, and indicate am/pm:

11:00 A.M - 11:00 P.M

Are any forms of entertainment offered or available within the licensed business or on the proposed designated portions of the premises?

Yes No

If "Yes", describe the entertainment offered or available:

LIVE BAND, D.J. OR KARAOKE - SATURDAY/SUNDAY 3:00 PM - 11:00 PM
 LIVE BAND, D.J. OR KARAOKE - MONDAY - FRIDAY 7:00 PM - 11:00 PM
 FRIDAY NIGHTS ARE "TEEN NITE" NO ALCOHOL CONSUMED OR SOLD ON PREMISES?

Food and beverage service offered or anticipated is:

table service buffet service counter service other

If "other", describe the manner of food and beverage service offered or anticipated:

Is an owner, manager, or assistant manager 21 years of age or older always present on the premises during business hours?

Yes No

Blueprints, CAD drawings, or other clearly drawn and marked diagrams may be submitted in lieu of the third page of this form.

I have attached blueprints, CAD drawings, or other supporting documents in addition to, or in lieu of, the third page of this form that meet the requirements of this form.

Yes No

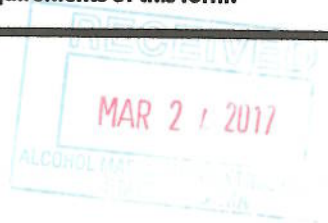



Alaska Alcoholic Beverage Control Board

Form AB-03: Restaurant Designation Permit Application

Alcohol and Marijuana Control Office
550 W 7th Avenue, Suite 1600
Anchorage, AK 99501
alcohol.licensing@alaska.gov
<https://www.commerce.alaska.gov/web/amco>
Phone: 907.269.0350

Section 4 – Detailed Floor Plan

Provide a detailed floor plan that meets the requirements listed in Form AB-01 and clearly indicates the proposed designated and undesignated areas of the licensed business for purposes of this permit application.

SEE ATTACHED
DIAGRAMS



GLEN THOMAS
RESTAURANT DIAGRAM
RED LINING ALCOHOL SERVING/CONSUMING
AREAS STORAGE

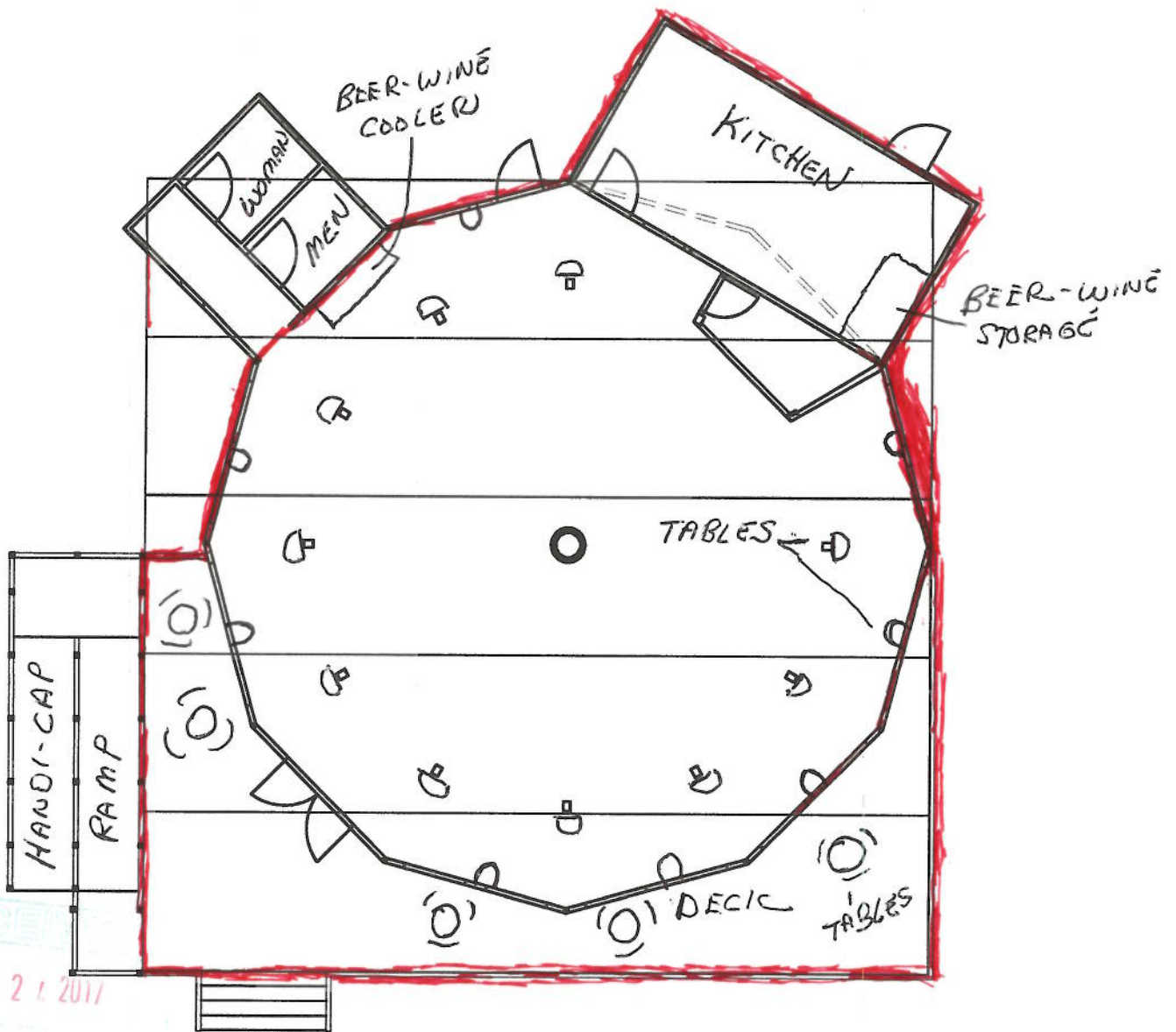

RECEIVED
MAR 21 2011
ALCOHOL SERVING/CONSUMING
STATE

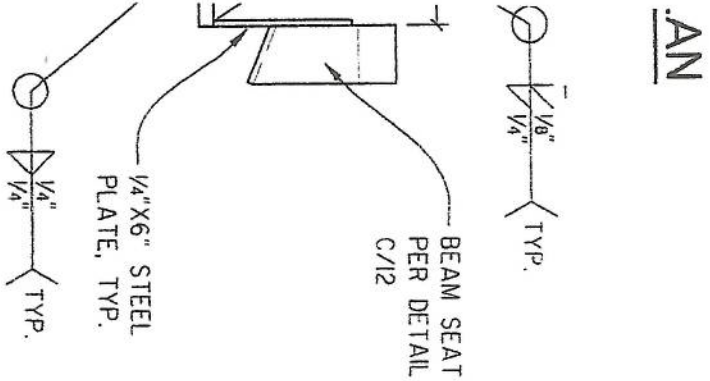

1/4"X6" STEEL PLATE, TYP.
 1/4"X6" STEEL PLATE, TYP.

ALL NEW
 I. MICRO WAVE
 II. MULTI-PURPOSE OVEN
 III. PIZZA PREP TABLE
 IV. REFRIGERATOR
 V. UPRIGHT FREEZER
 12' X 24' KITCHEN

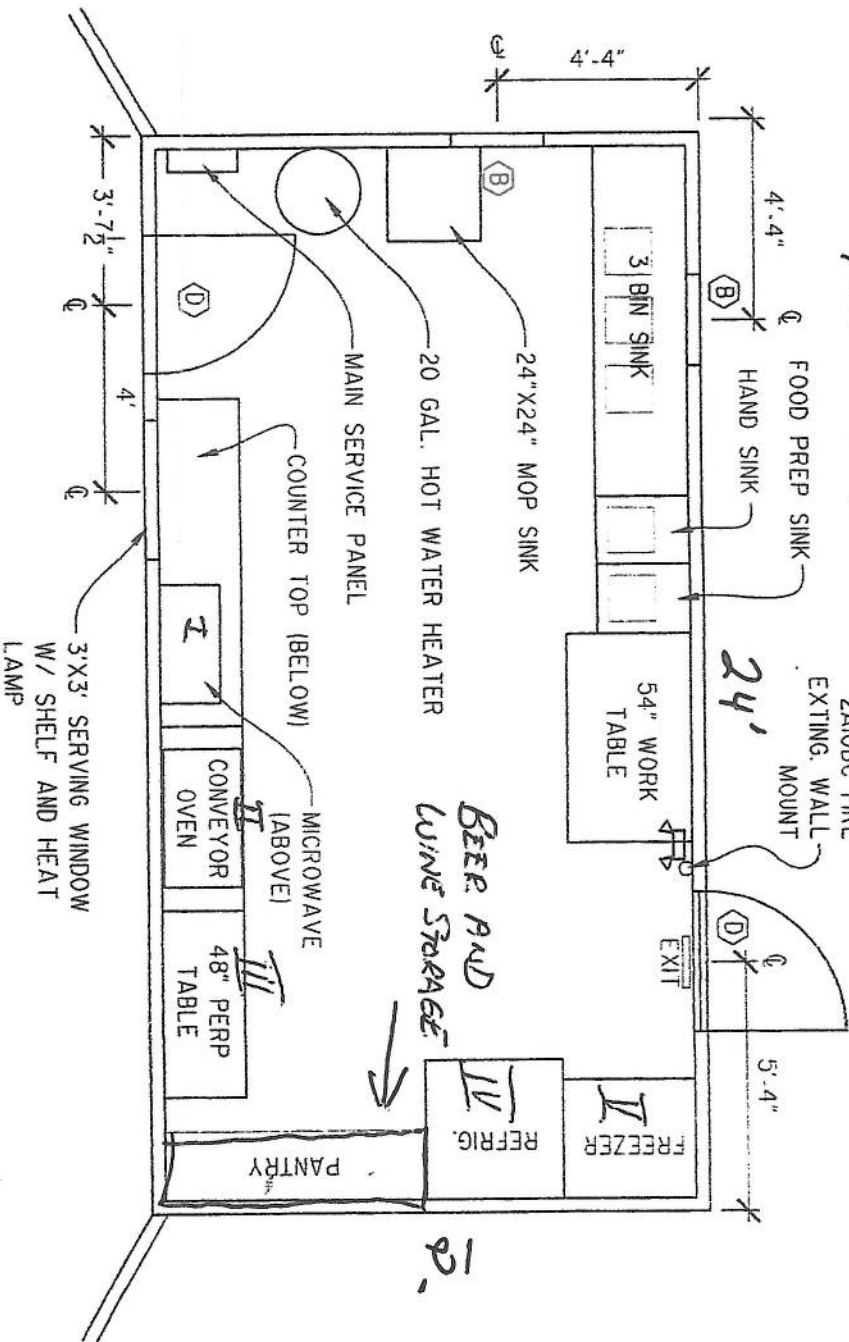

RECEIVED
 MAR 21 2011

GAZEBO UPGRADE
 GLEN THOMAS
 NINILCHIK, ALASKA
 DETAILS

PROJECT NO. 1614
 DRAWN BY: ZSR
 CHECKED BY: WJN
 DATE: 6/29/2016
 SCALE: NOTED

NELSON



Alaska Alcoholic Beverage Control Board

Form AB-03: Restaurant Designation Permit Application

Alcohol and Marijuana Control Office
550 W 7th Avenue, Suite 1600
Anchorage, AK 99501
alcohol.licensing@alaska.gov
https://www.commerce.alaska.gov/web/amco
Phone: 907.269.0350

Section 5 - Certifications and Approvals

Read each line below, and then sign your initials in the box to the right of each statement:

Initials

I have included with this form a detailed floor plan of the proposed designated and undesignated areas of the licensed business for purposes of this application. I understand that this diagram is different than my licensed premises diagram.



I have included with this form a menu, or an expected menu, listing the meals to be offered to patrons.



I certify that the license for which I am requesting designation is either a beverage dispensary, club, recreational site, golf course, or restaurant or eating place license.



I declare under penalty of perjury that this form, including all attachments and accompanying schedules and statements, is true, correct, and complete.

Signature of licensee (handwritten signature)

Signature of licensee

GLEN THOMAS

Printed name of licensee

Signature of Notary Public (handwritten signature)

Signature of Notary Public

Notary Public in and for the State of Florida

My commission expires: Dec 28-2018

Subscribed and sworn to before me this 22 day of March, 2017.

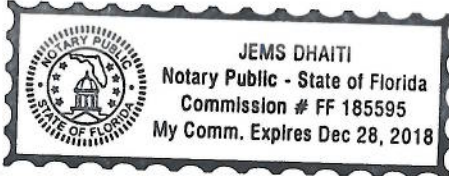

Local Government Review (to be completed by an appropriate local government official):

Approved Disapproved



Signature of local government official

Date

Printed name of local government official

Title

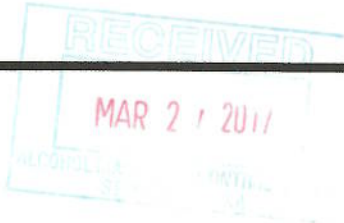



Alcohol and Marijuana Control Office
550 W 7th Avenue, Suite 1600
Anchorage, AK 99501
alcohol.licensing@alaska.gov
<https://www.commerce.alaska.gov/web/amco>
Phone: 907.269.0350

Alaska Alcoholic Beverage Control Board

Form AB-03: Restaurant Designation Permit Application

AMCO Enforcement Review:

Signature of AMCO Enforcement Supervisor

Printed name of AMCO Enforcement Supervisor

Enforcement Recommendations:

AMCO Director Review:

Approved Disapproved

Signature of AMCO Director

Printed name of AMCO Director

Date

Limitations:

RECEIVED

MAR 21 2017

ALCOHOL MARIJUANA CONTROL OFFICE
550 W 7TH AVENUE, SUITE 1600
ANCHORAGE, AK 99501
907.269.0350

MENU

GLEN THOMAS

D.B.A. NINILCHIK 132.6 CABINS & R.V. PARK
GOODY 2 SHOES RESTAURANT

EXPECTED MENU

PIZZA

BAR-B-QUE⁶

PULLED PORK PLATE

PULLED PORK SANDWICHES



MENU

EXHIBIT 11 of 13

GLEN THOMAS

D.B.A. NINIKCHIK 132.6 CABINS & R.V. PARK
GOODY 2 SHOES RESTAURANT

EXPECTED MENU

PIZZA

BAR-B-QUE⁶

PULLED PORK PLATE

PULLED PORK SANDWICHES

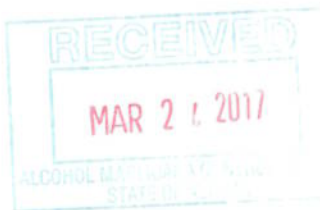

GLEN THOMAS
APPLICATION SUBMITTALS
By EXHIBIT NUMBER

EXHIBIT#

1. NEW LIQUOR LICENSE APPLICATION
2. POSTING AFFIDAVIT 2 (1 LICENSEE + 1 POSTING PERSON)
3. PROOF OF ADVERTISING (CLARION)
4. PROOF OF TITLE (WARRANTY DEED)
- ~~5.~~
5. STATEMENT OF FINANCIAL INTEREST
6. PREMISES DIAGRAM
7. FINGER PRINT CARDS (2) (LICENSEE + SPOUSE)
8. LICENSE FEE - \$ 300.00 CHECK# 1350
9. APPLICATION/FILING FEE \$ 100.00 CHECK# 1351
10. ALCOHOL SERVER TRAINING CERTIFICATION
11. MENU (ALSO INCLUDED WITH EXHIBIT 12)
12. RESTAURANT DESIGNATION PERMIT APPLICATION
(INCLUDES MENU, 2017 ALASKA FOOD PERMIT, ALASKA BUSINESS LIC.)
13. AUTHORIZATION OF RECORDS RELEASE (2)
1 - LICENSEE + 1 - SPOUSE

